

Low Voltage, High Current

With **Peak 100VDC and 200A output (20kW)**, the DYN2X servo drive delivers high power for even the most demanding applications. Perfectly suited for robotic and remote installations.

Control Versatility

In addition to all standard digital/analog and ethernet control types, the new DYN2X also supports up to 20-bit encoders in multiple protocols. Dual-Loop control is also supported. Auxiliary power for back-up logic control.

Optimal Servo Control

Existing market proven DMM DYN servo drive control is used. Combined with advanced AI assisted real-time auto-tuning and 30us position control loop, the best servo performance can be ensured.

Integrated Safety

STO, FSoE, integrated brake control, integrated regenerative circuit ensures safe operation. Dedicated safety circuit and connectors for reliable safety operation.



**100VDC
200A
Peak!**

Pulse/Analog Modbus TCP EtherNet/IP EtherCAT

Model# DYN2XR-	T1	TL	TH	TJ	TK
Main DC Power	24~100VDC ± 10%				
Auxiliary Power	12~24VDC ± 10% (0.5A Max.)				
Rated Current	10A	25A	50A	75A	100A
Peak Current	20A	50A	100A	150A	200A
Servo Modes	Position, Speed, Torque. On the fly changeable servo mode.				
Communication Option	Pulse, Analog, Modbus TCP, EtherCAT (CoE402), EtherNet/IP, CANbus				
Encoder Option	DMM 16/20-bit single/multi-turn encoder. Incremental ABZ Max 1Mhz. Halls. Resolver.				
Digital Inputs	Pulse Command, , Enable, Home, Reset, Limit Switch, Indexing				
Digital Outputs	ABZ Encoder Output, Alarm, Brake, Reset, Limit Switch, Indexing				
Analog Inputs	Speed, Torque, Position Analog Control. ±10VDC Analog. 12-bit resolution.				
Analog Outputs	Absolute Position, Position Error, Torque Analog Output Monitor				
STO	2-Stage, 24VDC, Dedicated Hardware STO Circuit. STO Status Output.				
Certification	CE, UL, TUV (All Certifications pending Sept 2025)				
Protection	IP67, 1G Vibration, Encapsulated Option Available				
Environment	-20 ~ 65°C Operating Temperature, 95RH% (no dew) Humidity.				

All Dimensions in [mm]

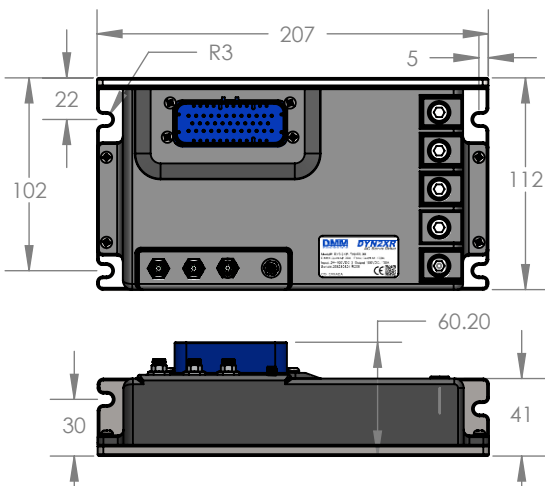

DYN2XR - T H A 6 S - 00

